



charnwood
country
16b WOODBURNER MKII
Operating & Installation Instructions

country *16b woodburner* **CONTENTS**

OPERATING INSTRUCTIONS

Fuel	3
Door Operation	3
Grate	3
Lighting	3
Controlling the Fire	4
Riddling	4
Refuelling	4
Ash Clearance	4
Overnight Burning	4
Cleaing and Maintenance	5
Throat Plate and Flueway Cleaning	5
Chimney sweeping	5
Trouble Shooting	6

INSTALLATION INSTRUCTIONS

Health & Safety Precautions	8
Performance	8
Specification	8
Chimney	8
Hearth & Fire Surround	9
Central Heating Sytem	10
System Controls	11
Connection to Flues	11
Soot Doors	11
Thermostat	12
Pre Lighting Check	12
Commissioning	12
Dimensions	13
Parts Lists	14
Certification	15

Before lighting the stove check with the installer that the work and checks described in the Installation Instructions have been carried out correctly and that the chimney has been swept, is sound and free from any obstructions. Do not light the fire before the boiler and heating system have been filled with water as this can damage the boiler.

If the stove is to be used where children and old or infirm people are present, then a fireguard manufactured in accordance with BS6539 must be used.

When the stove is under fire an aerosol spray must not be used in the vicinity.

FUEL

This stove is intended for burning only wood. Only dry well seasoned wood should be burnt as burning wet unseasoned wood will give rise to heavy tar deposits in the stove, on the glass and within the chimney. For the same reason hard woods (such as Ash, Beech and Oak) are better than soft woods (such as Pine and Spruce). Burning wet unseasoned wood will also result in considerably reduced outputs. The wood should be cut and split and then left to season in a well ventilated dry place for at least one year but preferably two years before use.

HETAS Ltd. Appliance Approval only covers the use of Wood Logs on this appliance.

DOOR OPERATION

Take care not to touch the doors as they will be hot when the fire is burning. The stove is normally run with the doors shut, and the doors must be shut if the stove is unattended.

Use the door opening and ashpan tool to open and close the doors. Turn the right-hand door knob anti-clockwise to open and clockwise to close (see Fig.1).

GRATE

Your Charnwood is fitted with a multi grate to enable wood to be burned and ash to be cleared. The grate has two positions:

1) In the open position the grate bars are vertical with gaps in between allowing the primary combustion air to come up

through the grate and through the fuel bed. This can be useful for quick lighting.

2) In the closed position the grate bars are horizontal, allowing the combustion air to come round the sides of the grate and over the top of it. When in the closed position ash is able to build up on the grate as is necessary for effective wood burning.

Movement of the grate from one position to the other is effected using the tool supplied as shown in Fig. 2. The grate is put into the open position by moving the tool up until the handle is in the 1 o'clock position. The grate is put into the closed position by moving the tool down until the handle is in the 5 o'clock position. To riddle the appliance the tool should be moved between the 1 o'clock and 3 o'clock positions several times. When burning wood logs the ash should be allowed to build up and riddling should only be carried out once or twice a week.

LIGHTING

Light the stove using dry kindling wood and paper or fire lighters. Set the grate into either the closed position or the open position as required. Place the paper, or fire lighters, and kindling on the grate and cover with a few small dry logs. Open the airwash and thermostat controls fully (see Fig. 1). Light the paper or fire lighters. Close the doors until the fuel is well ignited then load with fuel. Once the fire is up to temperature the airwash system will begin to work, so allow the fire to become hot before adjusting the air controls to the

Fig.1 Stove Controls

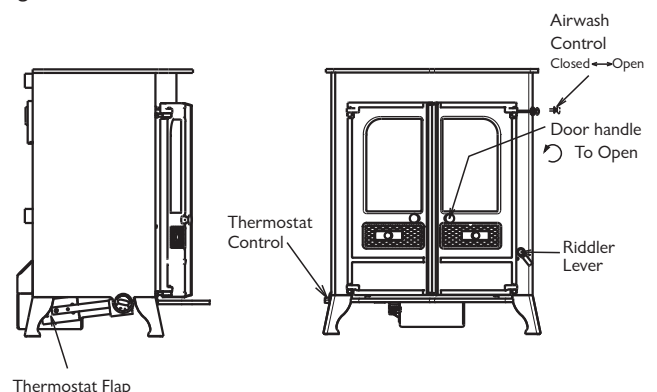

required setting. A flue pipe thermometer is available which will help you to get the best from your stove.

On initial lighting, the stove may smoke and give off an odour as the silicon paint with which the firebox is painted reacts to the heat. This is normal and will cease after a short time, but meanwhile the room should be kept well ventilated.

When relighting the stove, riddle slightly and then empty the ashpan.

CONTROLLING THE FIRE

The rate of burning and hence the output is regulated by the control knob on the side of the fire and the airwash control (see Fig.1).

The control knob is linked to a thermostat which senses the boiler temperature. The number at the front of the knob is the number at which it is set.

The airwash control should be kept at least slightly open most of the time to keep the glass clean. It may be fully opened when rapid heating is required or to help clean any deposits from the glass. It will not be possible to keep the glass clean if this control is fully closed, particularly immediately after refuelling.

For correct firing we recommend the use of a stove pipe thermometer which may be purchased from your supplier or from ourselves.

RIDDLING

When burning wood logs ash should be allowed to build up and only riddled when the ash begins to cover the slots in the rear fireplate. The fire should be riddled with the doors shut (see Fig. 2). Place the tool onto the riddling lever and rotate between the 1 o'clock and 3 o'clock positions several times. Too much riddling can result in emptying unburnt fuel into the ashpan and should therefore be avoided. After riddling, the grate should be put back into the open or closed position as required (the tool should be in the 1 o'clock position for open grate or in the 5 o'clock position for closed grate).

REFUELLING

Keep the firebox well filled but do not overfill to prevent fuel from spilling over the top of the front fire bars.

Take especial care that logs do not project over the front fire bars or damage to the glass may be caused when the doors are closed, it can also cause the glass to black up. Maximum filling height is such that logs cannot fall from the fire when the doors are opened. Liquid fuels are not to be used on this stove.

Fig 2. Grate Operation

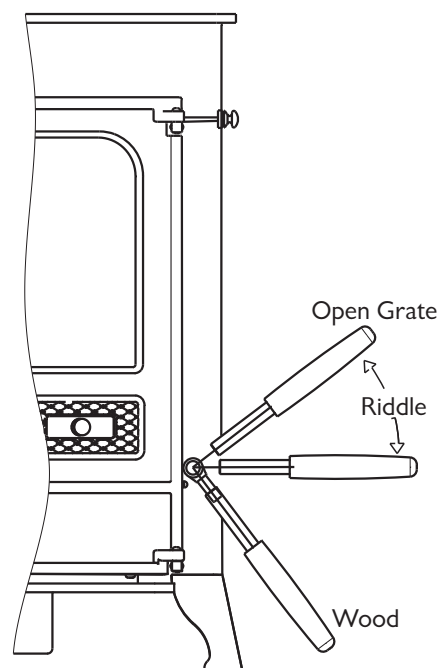

ASH CLEARANCE

The ashpans should be emptied regularly before it becomes too full. Never allow the ash to accumulate in the ashpans so that it comes in contact with the underside of the grate as this will seriously damage the grate bars. The ashpans are handled using the tool provided. Care should be taken to ensure that ash is cool before emptying it into plastic liners or bins.

To make ash removal easier there is a special Charnwood ash carrier available. This may be purchased from your supplier or, in case of difficulty, directly from ourselves.

OVERNIGHT BURNING

For overnight burning the fire doors must be closed. Use large logs rather than small ones.

If the fire is very low then it may be necessary to add a little fuel and turn the thermostat control up to maximum for a brief period until the fire is burning brightly before filling with fuel. When the new fuel has ignited, the thermostat control should be turned down to the required setting and the airwash control moved to a low setting. If the central heating pump is off overnight then the thermostat may be left at the same setting for both day and night operation. If the central heating pump is on overnight then set the thermostat control to give the required level of heating. Some experimentation will be necessary to find the settings most suitable for the particular fuel used and the draw on the chimney.

To revive the fire, add some small logs and open the air controls to maximum. When the fire is burning well load on more fuel as necessary and move the air controls to the desired setting.

CLEANING AND MAINTENANCE

The stove is finished with a high temperature paint which will withstand the temperatures encountered in normal use. This may be cleaned with a damp lint-free cloth when the stove is cold. Should re-painting become necessary, high temperature paints are available from your supplier or from stove shops.

The glass in the doors is a zero expansion ceramic glass, capable of withstanding the heat of the fire. Before cleaning the glass open the doors and allow them to cool. Clean the glass using a damp cloth and then wiping over with a dry cloth. Any stubborn deposits on the glass may be removed with a proprietary stove glass cleaner or ceramic hob cleaner. Some deposits on the glass may be burnt off simply by running the fire at a fast rate for a few minutes. Do not use abrasive cleaners or pads as these can scratch the surface which will weaken the glass and cause premature failure.

If the appliance is to be shut down for a prolonged period then the ash should be emptied and the interior of the firebox

cleaned out. The interior, including all moving parts, should be sprayed with a lubricant/corrosion inhibitor such as WD40. During this period the fire doors should be left ajar and the air controls open to allow air circulation through the appliance to minimise corrosion.

THROAT PLATE AND FLUEWAY CLEANING

It is important that the throat plate and all the stove flueways are kept clean. They should be cleaned at least once a week, and more frequently if necessary. It is necessary to let the fire out to carry out these operations.

The throat plate is lowered by hand. First, swing the throat plate bracket to the side. Lift the throat plate up from its locating pegs, pull it towards you, then lower as shown in Fig. 3. Any sooty deposits should then be swept from the plate and into the fire.

While the throat plate is lowered clean any sooty deposits from the boiler faces and the airwash tubes. Return the throat plate to its correct position - raise the front of the plate, push it back and then lower it onto the retaining lugs.

Fig. 3 Throat Plate Location

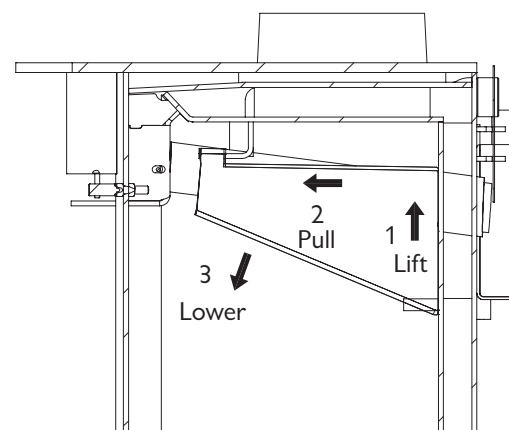

CHIMNEY SWEEPING

The chimney should be swept at least twice a year. Where a top outlet is used it will generally be possible to sweep the chimney through the appliance.

First remove the side fire plates, front firebars and the throat plate. Then sweep the chimney ensuring that soot is removed

from all horizontal surfaces after sweeping.

In situations where it is not possible to sweep through the appliance the installer will have provided alternative means, such as a soot door. After sweeping the chimney the appliance flue outlet and the flue pipe connecting the stove to the chimney must be cleaned with a flue brush.

After clearing any soot from within the stove, replace the throat plate (see Fig. 3), the front firebars, and side fireplates.

Different types of sweep's brushes are available to suit different flueways. For prefabricated insulated chimneys the manufacturers instructions with regard to sweeping should be consulted.

If the chimney previously served an open fire, it is possible that the higher flue gas temperature from the stove may loosen deposits that were previously firmly adhered, with the consequent risk of flue blockage. It is therefore recommended that in this case the chimney be swept a second time within a month of regular use after installation.

TROUBLE SHOOTING

Fire Will Not Burn

Check that:

- the air inlet is not obstructed in any way,
- chimneys and flueways are clear,
- a suitable fuel is being used,
- there is an adequate air supply into the room,
- an extractor fan is not fitted in the same room as the stove,
- there is sufficient draw in the chimney (once the chimney is warm a draught reading of at least 0.10 inches water gauge or 25 pa. should be obtained).

Blackening of Door Glass

Keeping the glass clean requires a certain amount of experimentation due to the differences in the draw of different chimneys. The following points should be noted and with a little care should enable the glass to be kept clean in most

situations:

- The airwash relies on a supply of heated air to keep the glass clean, therefore, when lighting the stove allow the fire to become well established before closing the air controls. This may also be necessary when re-fuelling the stove. Using a stovepipe thermometer will help you to operate the stove at the optimum temperature.
- When re-fuelling, keep the fuel as far back from the front firebars as possible, do not try to fit too much fuel into the firebox.
- Never completely close the airwash control - as a guide it should be at least a quarter open.
- Wet wood or logs overhanging the front firebars will cause the glass to blacken.

It is always more difficult to keep the glass clean when running the stove very slowly for long periods.

If blackening of the glass still occurs check that all flue connections and the blanking plate are well sealed. It is also important that the chimney draw is sufficient (when the chimney is warm a draught reading of at least 2.54 mm, or 0.10 inches water gauge or 25pa. should be obtained), and that it is not affected by down-draught.

Fume Emission

Warning Note: Properly installed and operated this appliance will not emit fumes. Occasional fume from de-ashing and re-fuelling may occur. Persistent fume emission is potentially dangerous and must not be tolerated. If fume emission does persist, then the following immediate actions should be taken:

- Open doors and windows to ventilate the room.
- Let the fire out and safely dispose of the fuel from the appliance.
- Check for flue or chimney blockage, and clean if required.
- Do not attempt to re-light the fire until cause of fume has been identified, if necessary seek professional advice.

The most common cause of fume emission is flueway or chimney blockage. For your own safety these must be kept clean.

Fire blazing out of control

Check that:

- a) the doors are tightly closed.
- b) the air controls are set at the minimum setting.
- c) the thermostat flap is closed (at the bottom of the left hand side of the appliance, see Fig. 1) and that it is not prevented from closing completely,
- d) the airwash control is closed,
- e) a suitable fuel is being used,
- f) door seals and airwash slide are intact.

Over-Firing

If the fire is over-fired it will cause premature failure of the internal fire parts. Overfiring is occurring when any parts of the fire begin to glow red. To prevent over-firing ensure that:

- a) the door seals are kept in good condition, and that the doors are sealing correctly,
- b) the thermostat on the fire is working correctly,
- c) a suitable fuel is being used,
- d) the fire is not fitted onto a heating system which is too large.

Freezing

Do not light the fire if there is any possibility that any parts of the system may be frozen.

Lack of Heat To Radiators / Hot Water

Check that:

- a) the fire is burning properly - if not then carry out the checks under "Fire Will Not Burn".
- b) the throat plate is fitted correctly (see Fig. 3) and that it is not distorted.

- c) the door seals are in good condition.

If the hot water goes cold when the pump is turned on, or if some radiators are hotter than others, then the system may need balancing, the pump may be pumping the water too quickly around the system, or the radiators may need bleeding. Please ask your installer to check these points.

Chimney Fires

If the chimney is thoroughly and regularly swept, chimney fires should not occur. However, if a chimney fire does occur turn the controls to the minimum setting, and tightly close the doors of the appliance. This should cause the chimney fire to go out in which case the controls should be kept at the minimum setting until the stove has gone out. The chimney and flueways should then be cleaned. If the chimney fire does not go out when the above action is taken then the fire brigade should be called immediately.

After a chimney fire the chimney should be carefully examined for any damage. Expert advice should be sought if necessary.

HETAS Ltd Approval

This appliance has been approved by HETAS Ltd. as a continuous operating appliance for burning Wood Logs and Smokeless Fuel only.

HEALTH AND SAFETY PRECAUTIONS

Please take care when installing the stove that the requirements of the Health and Safety at Work Act 1974 are met.

Some types of fire cement are caustic and should not be allowed to come into contact with the skin. In case of contact wash with plenty of water.

If there is a possibility of disturbing any asbestos in the course of installation then please use appropriate protective equipment.

There must not be an extractor fan fitted in the same room as the stove as this can cause the appliance to emit fumes into the room.

There must be an adequate air supply into the room in which the appliance is installed totaling at least 60.5cm² (9.4 square inches) to provide combustion air. It must be supplied via a permanently open vent which must be positioned such that it is not liable to blockage. This is particularly necessary if the room is double glazed.

Do not light the fire before the boiler has been connected to the system and filled with water, as this can cause serious damage to the boiler.

In addition to these instructions the requirements of BS.8303 and BS EN 15287-1:2007 must be fulfilled. Local Authority Bylaws and Building Regulations regarding the installation of Solid Fuel burning appliances, flues and chimneys must also be observed, including those referring to national and European Standards.

Electrical connections to central heating controls shall be made by competent persons and shall meet the requirements of the current issue of British Standard BS7671 Requirements for Electrical Installations.

PERFORMANCE

The rated output of the Country 16B Woodburner is 8.6 kW (29,344 Btu/h) to water and 7.3 kW (24,909 Btu/h) to the room. The outputs were obtained burning wood logs over a

1.5 hour re-fuelling cycle with the doors closed.

The heat output to the room is directly proportional to the heat output to water.

The output will vary in proportion to the frequency of re-fuelling. With this in mind when sizing the heating system we recommend using a boiler output of 10kW as shown in Fig. 4.

SPECIFICATION

Fig. 4. Performance Chart

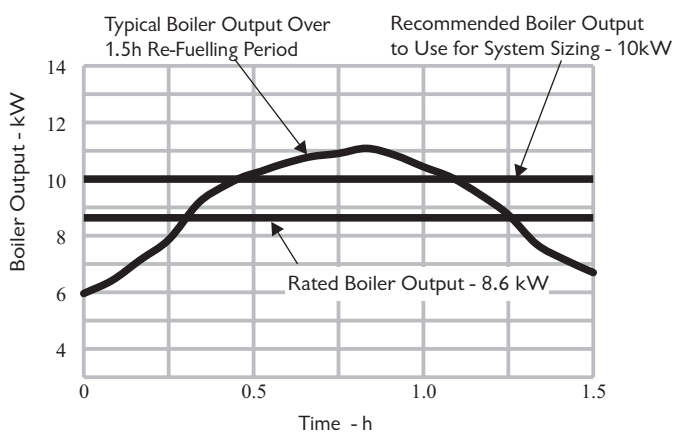

Country 16b	
Nominal Heat Output	15.9kw (54,250 Btu/h)
Space Heating Output	7.3kw (24,909 Btu/h)
Water Heating Output	8.6kw (29,344 Btu/h)
Max Water Pressure Bar	1.5 (50 foot water)
Boiler Volume	16.6 Litres
Min Distance from Combustibles plus sides and rear	150mm
Weight	180kg (b397l)
Normal Gas Temp.	284°C
Max Hearth Temp.	46°C
Min Flue Draught Pa	25 (0.1 in. water)
Flue Gas Mass Flow	11.6 g/s

CHIMNEY

In order for the appliance to perform satisfactorily the chimney height must not be less than 4 metres measured vertically from the outlet of the stove to the top of the

chimney. The internal dimensions of the chimney must not be less than 150 mm (6 inches) either square or round. This stove must not be used in a shared flue.

If an existing chimney is to be used it must be swept and checked, it must be in good condition, free from cracks and blockages, and should not have an excessive cross sectional area. If you find that the chimney is in poor condition then expert advice should be sought regarding the necessity of having the chimney lined. If it is found necessary to line the chimney then a lining suitable for Solid Fuel must be used.

If there is no existing chimney then a prefabricated block chimney or a twin walled insulated stainless steel flue to BS.4543 can be used either internally or externally. These chimneys must be fitted in accordance with the manufacturers instructions and Building Regulations.

Single wall flue pipe is suitable for connecting the stove to the chimney but is not suitable for using for the complete chimney.

If it is found that there is excessive draw in the chimney then a draught stabilizer should be fitted.

It is important that there is sufficient draw in the chimney and that the chimney does not suffer from down-draught. When the chimney is warm the draw should be not less than 2.54 mm (0.10 inches) water gauge. If in doubt about the chimney seek expert advice.

HEARTH AND FIRE SURROUND

The stove must stand on a fireproof hearth and must be situated at least 300mm (12 inches) from any combustible material. The positioning of the stove and the size of the hearth are governed by building regulations for Class 1 appliances. These building regulations state that the hearth must extend in front of the stove by at least 300mm (12 inches) and to the sides of the stove by at least 150mm (6 inches). If in doubt as to the positioning of the stove expert advice should be sought either from the supplier or the local building inspector.

The fireplace must allow good circulation of air around the

appliance to ensure that maximum heat is transferred to the room and also to prevent the fireplace from overheating. A gap of 150mm (6 inches) each side and 300mm (12 inches) above the appliance should give sufficient air circulation. If a wooden mantelpiece or beam is used in the fireplace it should be a minimum of 460mm (18 inches), and preferably 600mm (24 inches) from the appliance. In some situations it may be necessary to shield the beam or mantelpiece to protect it.

CENTRAL HEATING SYSTEM

The central heating system must comply with BS:5449 part 1.

If the system is to be a combined heating and domestic hot water system then a double feed indirect hot water storage cylinder to BS:1566 part 1 should be used. In order to prevent the build up of scale and corrosion a suitable inhibitor should be used. The system must be correctly vented as shown in Figs. 5 and 6. The height differential between the header tank and the appliance must not exceed 15.2 metres (50 feet).

If all four boiler tappings are used then, if possible, diagonal pairs should be connected for domestic hot water and central heating. Where a common return is used an injector tee must be incorporated into the system as shown in Fig. 7. This will ensure that a good domestic hot water supply is maintained when the central heating pump is operating.

The system must incorporate a gravity circuit which will normally heat the domestic hot water and an unvalved radiator with an output of at least 1 kW. When the appliance is not connected to a domestic hot water system the unvalved radiator(s) on the gravity circuit must have an output of at least 1.25 kW. This is to prevent boiling in case of pump failure. All pipework in the primary circuit must

be 28 mm diameter and the gravity flow pipe must rise continuously from the boiler to the open vent. Two typical systems are shown in Figures 5. and 6.

If the appliance is used to heat a small

central heating system then the heat output to the room from the fire will be reduced.

Fitting a radiator in the same room as the fire is recommended as it will allow greater flexibility in the way that the system is operated as well as ensuring that there is sufficient heat.

Connect the heating system to the boiler ensuring that the primary flow pipe rises continuously from the appliance to the vent. Fill the system with water and check for leaks.

Fig. 5. Typical Central Heating & Hot Water System Using 4 Boiler Tappings

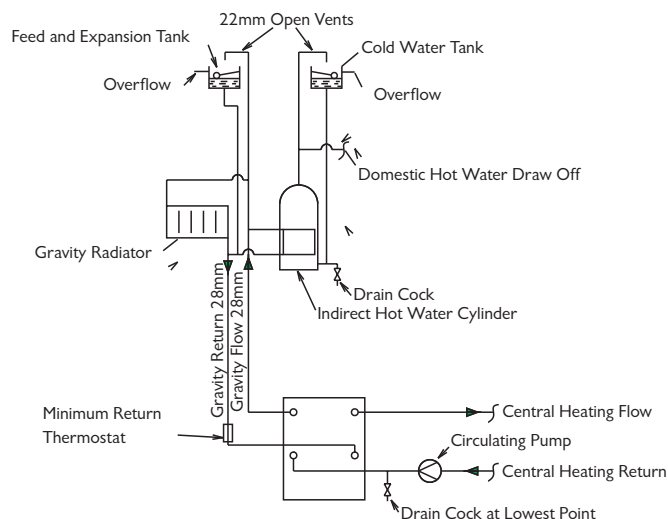

Fig. 6. Typical Central Heating & Hot Water System Using 3 Tappings

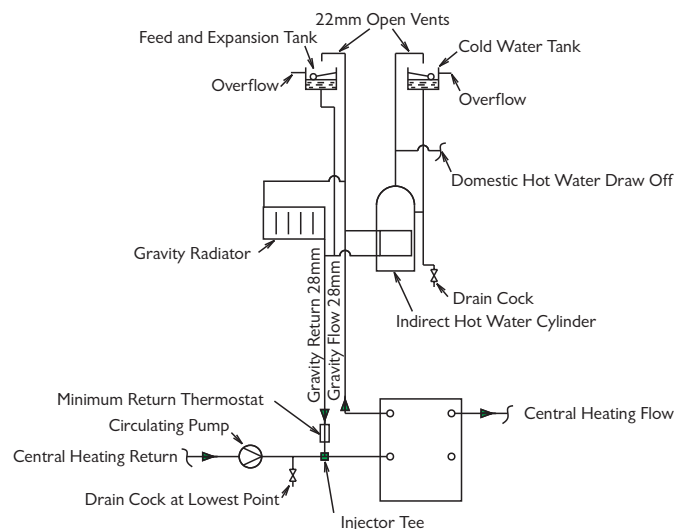
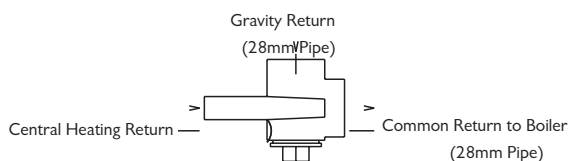

Fig. 7. Injector Tee.



SYSTEM CONTROLS

The circulating pump may be controlled by means of time switches, room thermostats or outdoor thermostats. Radiators may be either manually or thermostatically controlled. These controls will all work in conjunction with the thermostat on the appliance and the low limit pipe thermostat.

We recommend fitting a pipe thermostat onto the gravity return to act as a low limit thermostat. This should be wired into the mains supply to the pump so that if the gravity return temperature drops below 45°C then the pump will cut out. This will help to prevent condensation forming on the boiler faces and will thereby increase the life of the boiler. It will also ensure that priority is given to the domestic hot water. These thermostats are available from ourselves if you are unable to obtain them locally.

CONNECTIONS TO FLUES

There are several ways of connecting the stove to the flue. These are illustrated in figures 8 to 11.

If the optional vertical rear flue connector is used then the chimney may be swept through the appliance.

Horizontal lengths of flue must be kept to a minimum and must not be more than 150mm (6 inches) long. The sealing face of the flue collar must be coated with fire cement before fixing to the body of the stove using the two screws provided. The blanking plate must be removed, sealed with fire cement and refitted, care being taken to ensure that the fold on the clamping plate is in line with the lugs on the firebox as shown in Fig. 12. Ensure the clamping plate does not prevent the throat plate from seating correctly. All flue connections must be well sealed.

SOOT DOORS

It is possible to pass a 16 inch diameter sweeps brush through the appliance but in most back outlet installations unless the optional vertical rear flue adaptor is used it will be necessary to have a soot door to enable the chimney to be swept. This may either be in the actual brickwork of the chimney or in the

register plate. Various types and positions of soot doors are shown in figures 8 to 11.

Fig 8. Vertical Register Plate With Bricked Up Fireplace

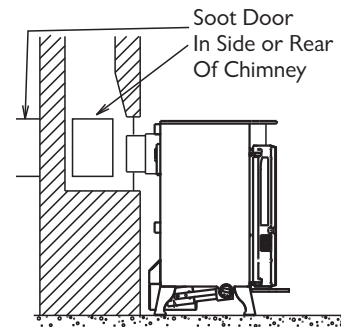

Fig 9. Horizontal Register Plate With Rear Flue Connection

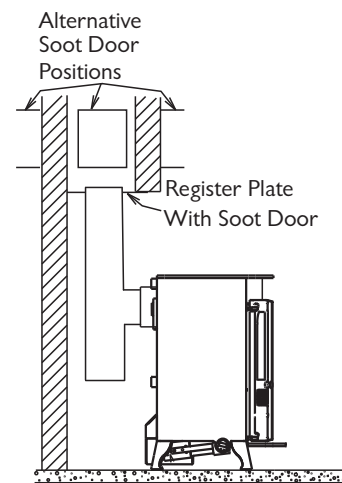

Fig 10. Horizontal Register Plate With Top Flue Connection

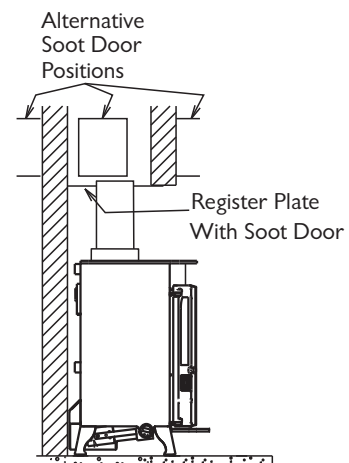

Fig. 11. Horizontal Register Plate With Optional Vertical Rear Flue Connector

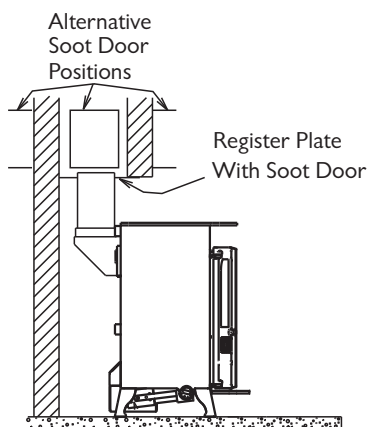

Fig. 12. Flue Blanking Plate.

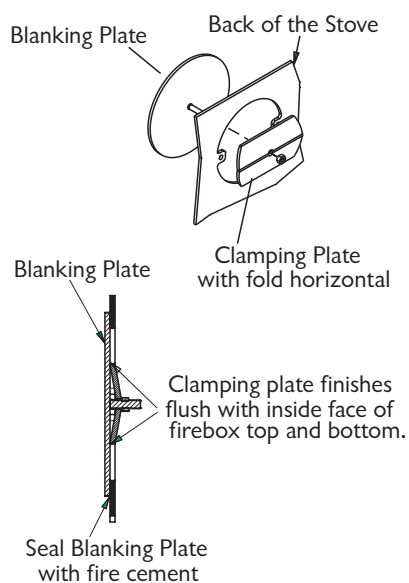
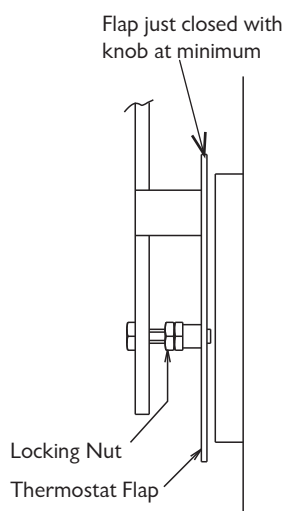

Fig. 13. Thermostat Setting



THERMOSTAT

Before lighting the fire check the cold setting distance of the thermostat. This is fitted under the firebox. Removing the Ash lip will give easier access.

With the control knob at the minimum setting the flap should be just closed, as shown in Fig. 13. To adjust the distance slacken the locking nut and adjust as necessary. When set correctly re-tighten the locking nut. Ensure that the flap opens and closes freely as the knob is turned, and that the opening is completely covered when the flap is closed.

PRE LIGHTING CHECK

Before initial lighting the following points should be checked:

1. The bottom grate bars must all be fitted and should move freely and easily when the riddling mechanism is operated.
2. The plates round the sides and back of the grate must be in position and sitting correctly.
3. The throat plate must be fitted in the roof of the appliance and should be checked to ensure that it has not become dislodged in transit. The method of location and positioning of the throat plate is shown in Fig. 3.

COMMISSIONING

On completion of the installation and after allowing a suitable period of time for the fire cement and mortar to dry out, the stove should be lit and checked to ensure that smoke and fumes are taken from the appliance up the chimney and emitted safely. Also check all joints and seals for soundness.

The central heating pump should be adjusted to give the correct water flow against the circuit resistance and the system should be correctly balanced.

On completion of the installation and commissioning please leave the operating instructions with the customer and advise on the use of the appliance and any controls on the system.

COUNTRY 16B WOODBURNING DIMENSIONS (mm)

Flue connection may
be Top or Rear

Boiler tappings are 1" BSP Female

Optional Vertical Rear Flue Connector

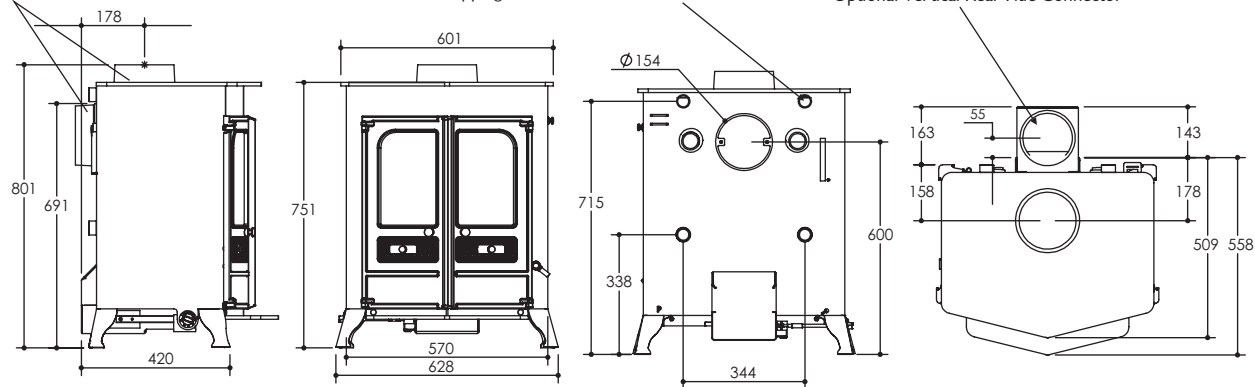

COUNTRY 16B WOODBURNING PARTS LIST

Issue G

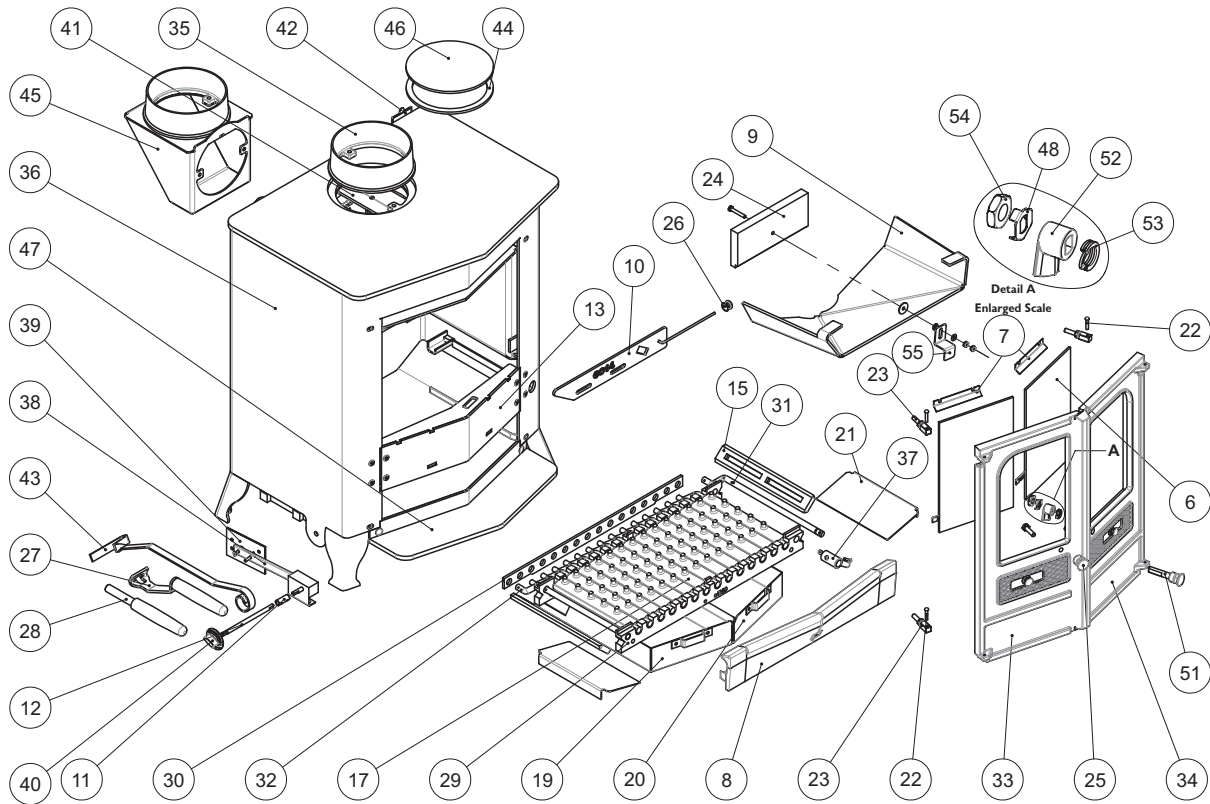

Item	Part No.	Description	Item	Part No.	Description
3*	008/GS35S	Door Seal Set Incl. Adhesive	30	012/BV33	Mover Bar
4*	008/FW29	Door Seal Adhesive	31	012/BV37	Riddler Rod
5*	008/RW55	Glass Seal Kit	32	012/CG05	Idler Rod
6	006/LW30	Glass (Inc Seal)	33#	002/FV01/A	Left Hand Door Assembly
7	004/GV23	Glass Retainer	34#	002/FV02/A	Right Hand Door Assembly
8	002/CS07	Wood Retainer	35	002/CH12B	Flue Collar
9	010/GS31	Throat Plate	36#	009/CO16BWB/A	Firebox/Boiler Assy
10	010/GS14	Secondary Air Slide	37	002/AY27	Riddler Knob
11	004/CS18	Thermostat Connector Tube	38	008/FW48	Thermostat
12	004/CS16	Thermostat Rod	39	008/FV49	Thermostat Flap
13	010/GS06	Front Middle Bar Assembly	40	008/BW50	Thermostat Knob
15	002/EW15	Side Fire Plate	41	010/AY51	Clamping Plate
16	002/BV16	Back Fire Plate	42	012/GS11W	Serial No. Label
17	002/CG01	Bottom Grate Bar	43	012/FW34	Scraper Tool
18	002/CG01S14	Set of Grate Bars (14 Per Set)	43	010/NV11	Flue Spacer Ring
19	004/FV17L	Left Hand Ashpan	45	010/TW33	Vert. Rear Flue Connector (Opt'l Extra)
20	004/FV17R	Right Hand Ashpan	46	012/TW09	Blanking Plate
21	004/BV19	Ash Shedding Plate	47	010/GS12	Shelf
22	008/BW39/S	Hinge Pin Set	48	004/ST008	Tabbed Locking Washer
23	008/FW27	Hinge Post	49*	010/BW51	Ash Carrier (Optional Extra)
24	011/GS29	Upper Throatplate Brick	50*	008/TH02/L	Low Level Pipe Stat (Opt'l Extra)
25	002/DY19	Left Hand Door Knob	51	002/DY18	R.H. Door Knob & Spindle
26	002/TW13	Air Control Knob	52	002/AY14	Door Catch Cam
27	012/BV20/A	Ashpan/Door Opening Tool	53	008/FFW015	M12 Double Coil Spring Washer
28	012/BV36/A	Riddling Tool	54	008/FFN001	M12 Half Nut
29	002/BV30	Carrier Bar	55	004/XV30	Brick Retaining Bracket

* These items are not shown on the drawing.
Please specify colour when ordering.

To obtain spare parts please contact your local stockist giving Model, Part No. and Description. In case of difficulty contact the manufacturer at the address shown.
This drawing is for identification purposes only.

charnwood



A.J WELLS & SONS LTD

09

Bishops Way, Newport, Isle of Wight PO30 5WS, United Kingdom

EN13240:2001

country

16_b woodburner

ROOMHEATERS & BOILER FIRED BY MULTI FUEL

EC certificate of
conformity no:

GS44-CPD-2009

Maximum operating
pressure:

1.5 bar

Minimum distance to
combustible materials
Side:
Rear:

150mm

150mm

Emission of CO in flue gases:

0.97%

Flue gas temperature:

284°C

Thermal output:

15.9kW

Space heating output:

7.3kW

Water heating output:

8.6kW

Energy efficiency:

75.0%

Fuel types:

Wood Logs

your premier dealer

REY COUNTRY 166 06 13 ISSUE F

