

**CHARNWOOD
LA20i
Roomheater**

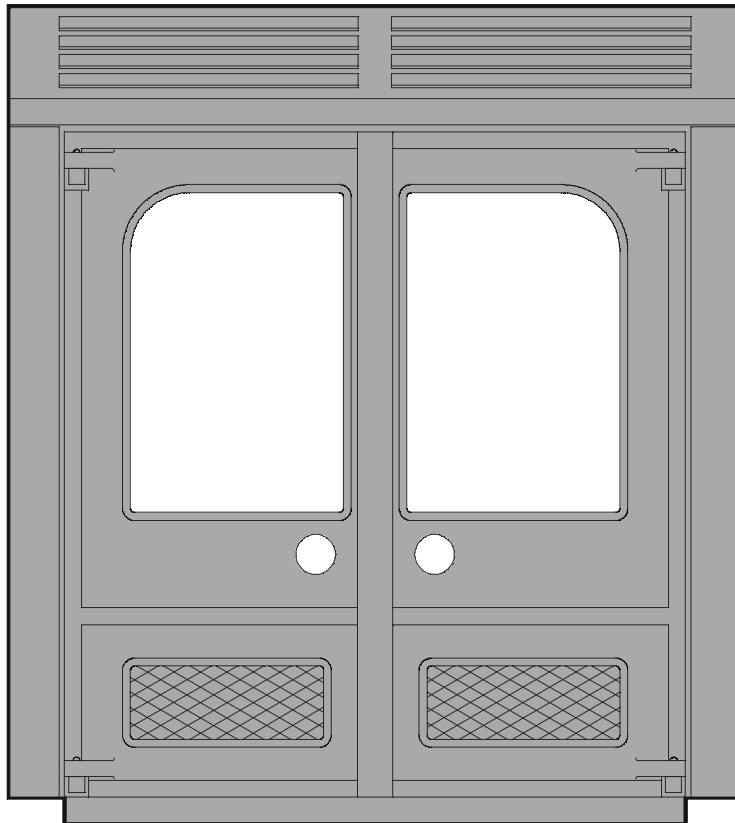

**Operating
and
Installation Instructions**



CHARNWOOD Bishops Way, Newport, Isle of Wight PO30 5WS, United Kingdom
T: +44 (0)1983 537799 F: +44 (0)1983 537788 charnwood@ajwells.co.uk www.charnwood.com

CHARNWOOD LA20i

Operating and Installation Instructions

Contents

Operating Instructions

General Points.....	3
Fuels.....	3
Door Operation	3
Lighting	3
Controlling The Fire	3
Running The Fire With The Doors Open	4
Ash Clearance	4
Riddling	4
Refuelling.....	4
Overnight Burning	4
Throat Plate & Flueway Cleaning	4
Maintenance	5
Chimney Sweeping.....	5
Trouble Shooting.....	5

Installation Instructions

Health & Safety Precautions	7
Performance	7
Chimney.....	7
Hearth	7
Preparation Of Fireplace.....	7
Fitting The Fire.....	7
Hot Water System.....	8
Fitting The Optional Add-In Boiler.....	8
Flue Connection & Infilling	9
Thermostat	9
Assembly.....	9
Pre-Lighting Check	9
Commissioning	9
Freestanding Kit.....	9
Overall Dimensions.....	10
Exploded Parts Drawing.....	11



OPERATING INSTRUCTIONS FOR THE CHARNWOOD LA20i

GENERAL POINTS

Before lighting the fire check with the installer that the work and checks described in the installation instructions have been carried out correctly and that the chimney has been swept, is sound, and free from any obstructions.

WARNING There must not be an extractor fan fitted in the same room as this appliance as this can cause the appliance to emit smoke and fumes into the room.

If the appliance is fitted in place of an open fire then the chimney should be swept one month after installation to clear any soot falls which may have occurred due to the difference in combustion between the appliance and the open fire.

When using the fire in situations where children or infirm people are present please use a fire guard to prevent accidents. The fire guard should be manufactured in accordance with BS 6539.

This appliance obtained approval by HETAS Ltd. in the safe and fit for purpose category.

FUELS

HETAS Ltd. approval only covers the use of the following smokeless fuels on this appliance:

Ancit (Phurnacite Plus),
Anthracite Large Nuts,
Cosycoke,
Centurion,
Extracite,
Maxibrite,
Phurnacite,
Sunbrite Doubles,
Welsh Dry Steam Coal (Large Nuts).

Approval does not cover the use of other fuels either alone or mixed with the above fuels, nor does it cover instructions for the use of other fuels.

The above fuels are all suitable for use in smoke control areas. In non-smoke

control areas your Housing Authority will be able to advise you if other fuels may be burnt. For instructions on burning other fuels please ask your supplier or Housing Authority for the "Charnwood Instruction Supplement."

PETROLEUM COKE IS NOT SUITABLE FOR USE ON THIS APPLIANCE, ITS USE WILL INVALIDATE THE GUARANTEE

At first you may find it helpful to try several fuels to find the most suitable. If you are unable to obtain the fuel you want ask your supplier, an approved fuel distributor, or the Solid Fuel Association (tel. 0800 600 000) to suggest an alternative.

DOOR OPERATION

Use the spanner type tool to open and close the doors. Turn the knob on the right hand door anti-clockwise to open and clockwise to close. When closing the doors do not push on the enamel with the tool as this can chip the enamel, instead push the doors on the door knobs.

LIGHTING

Place some paper and dry kindling wood or fire lighters on the grate and cover with a small amount of fuel. Turn the thermostat control knob to the maximum setting and light the paper or fire lighters. Close the doors and allow the fire to burn until the fuel is well ignited then load with more fuel and adjust the thermostat to the required level.

On initial lighting, the fire may smoke and give off an odour as the silicon paint with which the firebox is painted reacts to the heat. This is normal and will cease after a short time. In the meantime the room should be kept well ventilated.

Before relighting the fire, riddle,

remove any clinker from the firebed and empty the ashpan.

CONTROLLING THE FIRE

The rate of burning and hence the output is controlled by the control knob on the left hand side of the appliance, shown in Fig. 1. This is linked to a thermostat which controls the firebox temperature. The number at the top of the knob is the number at which it is set. Some experimentation may be necessary to obtain the desired heat output.

There is also a manual secondary air control which is located above the door opening as shown in Fig. 2. To adjust the setting, open the doors and use the door opening tool to move the flap to the desired position. This control should be in the closed position when burning any of the recommended smokeless fuels except

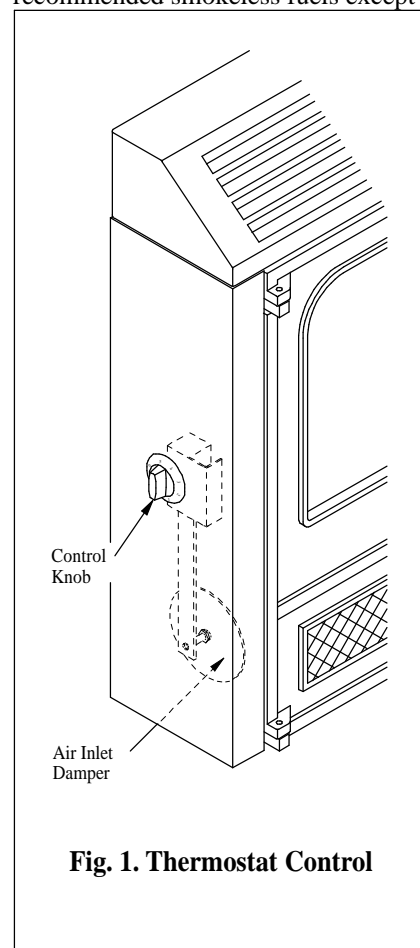

Fig. 1. Thermostat Control

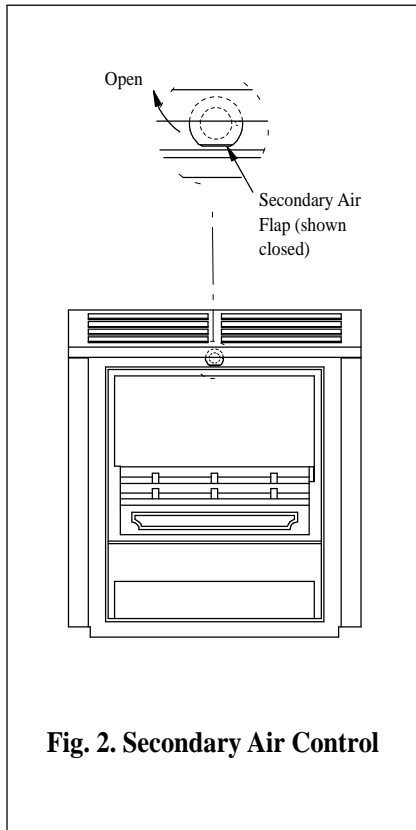

Fig. 2. Secondary Air Control

for anthracite and homefire which should be burnt with the secondary air inlet open.

RUNNING THE FIRE WITH THE DOORS OPEN

The fire may be run with the doors open. This will result in a reduction in efficiency and hence heat output. The more reactive fuels, like homefire, will burn better when the doors are open than fuels like phurnacite, sunbrite and ancit.

For safety reasons, if the fire is to be left unattended with the doors open then use a spark guard which complies with BS 3248.

ASH CLEARANCE

The ashpan should be emptied regularly before it becomes too full. The most convenient time to remove the ash is just before riddling the fire since the ash will then be at its coolest. Use the tool provided to remove the ashpan.

Never allow the ash to accumulate in the ashpan so that it comes in contact with the underside of the grate as this

will seriously damage the grate bars. Ensure that the air inlet damper is not prevented from closing by spilled fuel or ash.

Care should be taken to ensure that ash is cool before emptying it into plastic liners or bins.

To make ash removal easier there is a special Charnwood ash carrier available. This may be purchased from your supplier or, in case of difficulty, from ourselves.

RIDDLING

Riddling twice a day is usually sufficient.

The fire should be riddled with all doors shut. Place the tool on the knob and rotate between the horizontal and the 45 degree position several times as shown in Fig. 3.

Caution: when riddling the grate using solid fuel do not go beyond the 45 degree position as this can cause the grate to jam.

If jamming does occur then the fire should be allowed to burn for approximately half an hour before riddling the grate again as described above.

Too much riddling can result in emptying unburnt fuel into the ashpan and should therefore be avoided. Clinker should regularly be removed from the firebed.

After riddling, the grate should be put back into the solid fuel position (the tool should be horizontal).

REFUELLING

Keep the firebox well filled (the fuel may be sloped up from the front firebars), but do not allow fuel to spill over the top of the front fire bars. Take care that fuel does not project over the front fire bars or damage to the glass may be caused when the doors are closed.

OVERNIGHT BURNING

Empty the ashpan, if necessary, and then riddle the fire. If the fire is very low then it may be necessary to add a

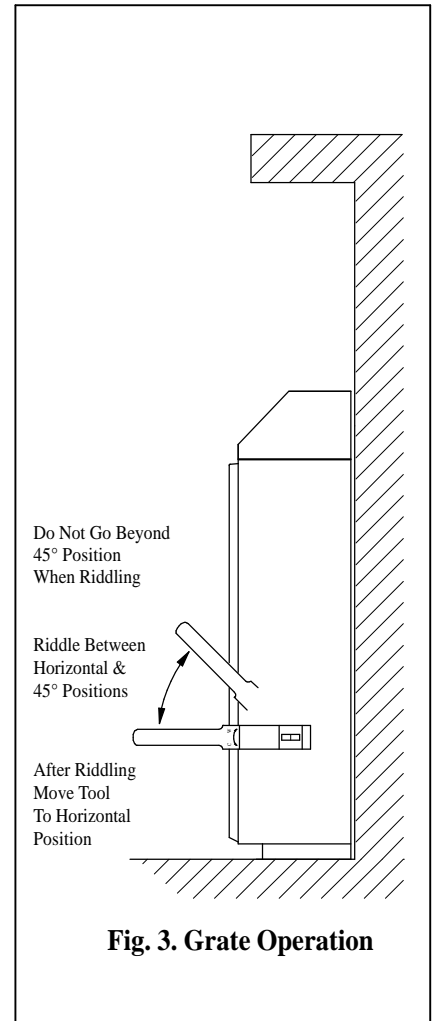

Fig. 3. Grate Operation

little fuel and turn the thermostat control up for a brief period until the fire is burning well before filling with fuel.

Some experimentation may be necessary to find the thermostat setting most suitable for the particular fuel used and the draw on the chimney, but generally the thermostat should be turned down to the minimum setting overnight.

For overnight burning the fire doors must be closed.

To revive the fire, empty the ashpan if necessary, riddle, and turn the thermostat control knob to maximum. When the fire is burning well load on more fuel as necessary and turn the thermostat to the desired setting.

THROAT PLATE AND FLUEWAY CLEANING

It is important that the throat plate and all the appliance flueways are kept clean. When burning smokeless fuels

they should be cleaned monthly. When burning other fuels they should be cleaned at least once a week, and more frequently if necessary.

The throat plate and flueways may be cleaned with a low fire still burning. Use the scraper tool to scrape any sooty deposits to the front of the plate until they fall off into the fire.

More soot will be deposited on the throat plate and in the flueways if the appliance is run at low levels for long periods. If this is the case then more frequent cleaning will be necessary.

MAINTENANCE

Cleaning

The appliance is finished in vitreous enamel. To clean the surfaces simply wipe over with a dry cloth. Abrasive pads and scouring cleaners must not be used as these will damage the finish. Care should be taken not to knock the enamel with hard objects as it will chip.

Cleaning the Glass

The glass in the doors is a special ceramic glass which is able to withstand high temperatures. Before cleaning the glass open the doors and allow them to cool. Clean the glass using a damp cloth and then wiping over with a dry cloth. Any stubborn deposits may be removed with a proprietary stove glass cleaner or ceramic hob cleaner. Some deposits on the glass may be burnt off simply by running the fire at a fast rate for a few minutes. Do not use abrasive cleaners or pads as these can scratch the surface which will weaken the glass and cause premature failure. Aerosol spray cleaners should not be used near the appliance whilst it is under fire.

When not in use

If the fire is going to be out of use for a long period (for instance in the summer) then to prevent condensation, and hence corrosion, the thermostat should be left at the maximum setting and the main doors left ajar. It is also advisable to sweep the chimney and clean out the fire. Spraying the inside of the doors and firebox with a light oil, such as WD40, will also help to keep all internal parts working well.

After long periods where the fire has

been out of use, the chimney and appliance flueways should be cleaned before lighting.

Door Seals

For the fire to operate correctly it is important that the door seals are in good condition. Check that they do not become worn or frayed and replace them when necessary.

Servicing

It is recommended that the fire is serviced once a year to keep it in first class working order. After cleaning out the firebox thoroughly, check that all internal parts are in good working order, replacing any parts that are beginning to show signs of wear. Check that the doors seals are in good condition and that the doors seal correctly. Check the operation of the thermostat, both when cold and hot. A servicing guide, TIS 48. is available on request.

CHIMNEY SWEEPING

The chimney should be swept at least twice a year. In most installations it will be possible to sweep the chimney through the appliance.

First remove the front firebars and the throat plate. Then sweep the chimney ensuring that soot is removed from all horizontal surfaces after sweeping.

In situations where it is not possible to sweep through the appliance the installer will have provided alternative means, such as a soot door. After sweeping the chimney the appliance flue outlet and the flue pipe connecting the appliance to the chimney must be cleaned with a flue brush.

After clearing any soot from within the fire, replace the throat plate and the front firebars.

Different types of sweep's brushes are available to suit different flueways. For standard brick chimneys a wire centre sweep's brush fitted with a guide wheel is recommended. For prefabricated insulated chimneys the manufacturers instructions with regard to sweeping should be consulted.

TROUBLE SHOOTING

Fire Will Not Burn.

Check that:

- a) the air inlet is not obstructed in any way,
- b) that chimneys and flueways are clear,
- c) that a suitable fuel is being used,
- d) that there is an adequate air supply into the room,
- e) that an extractor fan is not fitted in the same room as the fire.

Fire Blazing Out Of Control.

Check that:

- a) the doors are tightly closed,
- b) the thermostat knob is turned down to the minimum setting,
- c) the air inlet damper is closed (at the bottom left of the appliance), and that it is not prevented from closing completely by a piece of ash,
- d) a suitable fuel is being used,
- e) the door seals are in good condition.

Over-Firing

If the fire is over-fired it will cause premature failure of the internal fire parts. Overfiring is occurring when any internal parts of the fire begin to glow red. To prevent over-firing ensure that:

- a) the door seals are kept in good condition, and that the doors are sealing correctly,
- b) the thermostat on the fire is working correctly,
- c) a suitable fuel is being used.

Fume Emission.

Warning Note:

Properly installed and operated this appliance will not emit fumes. Occasional fume from de-ashing and re-fuelling may occur. Persistent fume emission is potentially dangerous and must not be tolerated. If fume emission does persist then the following immediate actions should be taken:

- A) Open doors and windows to ventilate the room.
- B) Let the fire out and safely dispose of fuel from the appliance.
- C) Check for flue or chimney blockage, and clean if required.

D) Do not attempt to relight fire until cause of fume has been identified, if necessary seek professional advice.

The most common cause of fume emission is flueway or chimney blockage. For your own safety these must be kept clean.

Freezing

If a boiler is fitted do not light the fire

if there is any possibility that any parts of the system may be frozen.

Chimney Fires.

If the chimney is thoroughly and regularly swept, chimney fires should not occur. However, if a chimney fire does occur turn the control knob to the minimum setting, and tightly close the doors of the appliance. This should cause the chimney fire to go out in which case the control should be kept

at the minimum setting until the fire in the appliance has gone out. The chimney and flueways should then be cleaned. If the chimney fire does not go out when the above action is taken then the fire brigade should be called immediately.

After a chimney fire the chimney should be carefully examined for any damage. Expert advice should be sought if necessary.

INSTALLATION INSTRUCTIONS FOR THE CHARNWOOD LA20i

HEALTH AND SAFETY

PRECAUTIONS

WARNING

Please take care when installing the appliance that the requirements of the Health and Safety at Work Act 1974 are met.

Some types of fire cement are caustic and should not be allowed to come into contact with the skin. In case of contact wash with plenty of water.

If there is a possibility of disturbing any asbestos in the course of installation then please use appropriate protective equipment.

There must not be an extractor fan fitted in the same room as the appliance as this can cause the appliance to emit fumes into the room.

There must be an adequate air supply into the room in which the appliance is installed totalling at least 100 square cm. (16 square inches) to provide combustion air. This is particularly necessary if the room is double glazed.

In addition to these instructions the requirements of BS:8303 and BS:6461 Pt 1&2; 1984 must be fulfilled. Local Authority Bylaws and Building Regulations regarding the installation of Solid Fuel burning appliances, flues and chimneys must also be observed.

PERFORMANCE

The rated output for the LA20i is 5.4 kW (18800 btu/h) to the room.

This is the output obtained burning Sunbrite Doubles at a rate of 1.0 kg/hr with the doors closed over a 4 hourly re-fuelling interval.

There is an optional add-in domestic hot water boiler available with an output of 2.0 kW (6800 btu/h). If this is fitted then the output to the room will be reduced by a corresponding amount.

CHIMNEY

In order for the appliance to perform satisfactorily the chimney height must not be less than 4 metres measured vertically from the outlet of the fire to the top of the chimney. The chimney should preferably be 175 mm (7 inches) or 200mm (8 inches) internal diameter or square with sides of 175mm or 200mm internally and **MUST NOT BE LESS THAN 150mm (6 INCHES) INTERNAL DIAMETER OR 150 x 150mm INTERNAL SQUARE.**

If an existing chimney is to be used it must be swept and checked, it must be in good condition, free from cracks and blockages, and should not have an excessive cross sectional area (e.g. greater than 250mm x 250mm). If you find that the chimney is in poor condition then expert advice should be sought regarding the necessity of having the chimney lined. If it is found necessary to line the chimney then a lining suitable for Solid Fuel must be used.

If there is no existing chimney then a prefabricated block chimney or a twin walled insulated stainless steel flue to BS:4543 can be used either internally or externally. These chimneys must be fitted in accordance with the manufacturers instructions and Building Regulations.

Single wall flue pipe is suitable for connecting the appliance to the chimney but is not suitable for using for the complete chimney.

If it is found that there is excessive draw in the chimney then a draught stabilizer should be fitted.

HEARTH

The appliance must be installed on a fireproof hearth and must be situated at least 300 mm (12 inches) from any combustible material. The positioning of the appliance and the size of the hearth are governed by building regulations for Class 1 appliances.

These building regulations state that the hearth must extend in front of the appliance by at least 300 mm (12 inches) and to the sides by at least 150 mm (6 inches). If in doubt as to the positioning of the appliance expert advice should be sought either from the supplier or the local building inspector.

PREPARATION OF FIREPLACE

Before fitting the appliance into an existing fireplace remove the fireback and any loose in-fill material.

The hearth, surround and opening for the appliance must conform with Figs. 4 and 5. The flat area around the opening must be a minimum of 750 mm wide and 660 mm high. Ensure that the hearth and the base in the opening are flat, level, and at right angles to the surround.

Make a hole in the front of the chimney breast to give access for infilling and fixing the flue pipe. If the optional boiler is to be fitted it will also be necessary to make a hole in the side of the chimney breast to give access for the pipework.

FITTING THE FIRE

In some cases it may be necessary to place the connecting flue pipe in the chimney before fitting the fire into the fireplace.

Apply fire cement to the rear face of the sealing flange on the appliance. Fit the appliance into the opening ensuring that it is central and that a good seal is made between the sealing flange and the face of the surround.

Remove any excess fire cement from around the sealing flange.

The appliance should be screwed to the hearth through the holes at the base of the sealing flange.

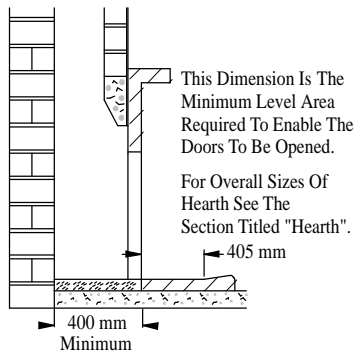
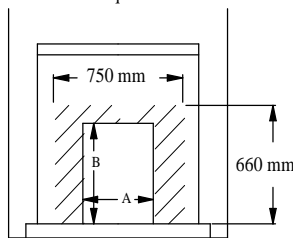

Fig. 4. Limiting Dimensions Of Hearth

The shaded area on the face of the surround is the minimum flat area required.



Dim. A:
Max. 470mm (18 - 1/2")
Min. 405mm (16")

Dim. B:
Max. 575mm (22 - 2/3")
Min. 555mm (21 - 3/4")

Fig. 5. Limiting Dimensions Of Surround And Opening

HOT WATER SYSTEM

The optional add-in boiler which may be fitted in the appliance has an output sufficient for domestic hot water heating. If the boiler is fitted then the room heating will be reduced.

The hot water system should be a gravity circuit and must be correctly vented as shown in Fig. 6.

The steel boiler in conjunction with a double feed indirect hot water storage cylinder to BS:1566 part 1 should be used in most situations, unless the

appliance is to be fitted in a soft water area in which case the stainless steel boiler may be used with a direct hot water cylinder.

All pipework in the primary circuit must be 28mm diameter and the flow pipe must rise continuously from the boiler to the open vent.

If an indirect cylinder is used then the primary circuit should be filled with a suitable inhibitor to prevent the build up of scale and corrosion.

FITTING THE OPTIONAL ADD-IN BOILER

The boiler replaces the rear firebrick and is reversible so that the 1" B.S.P. male tappings may come on either the left or the right hand side of the boiler.

The boiler tappings protrude from the sides of the appliance and it will therefore be necessary to fit the boiler into the appliance after positioning the appliance in the fireplace if the fire surround is already fitted.

Before fitting the boiler, remove the front firebars, the side and back fire plates and the firebricks. Knock out the knock-outs for the boiler tappings on the appropriate side of the firebox.

Remove the backnuts and fibre washers from the boiler tappings and fit the boiler into the appliance. Place the fibre washers over the tappings on the outside of the appliance and fit the backnuts, ensuring that the boiler is held tightly against the rear inside face of the appliance and that the top edge of the boiler is level or runs uphill to the flow tapping.

When re-fitting the firebricks, note that the short side firebrick supplied with the boiler must be fitted on the same side as the boiler tappings. One of the original side firebricks is fitted on the other side, and the rear firebrick is discarded. The firebricks must be fire cemented into position, wetting the firebox will improve the adhesion.

Replace the back fireplate, the side fireplates, the front firebar and the throat plate.

Connect the boiler to the heating system ensuring that the flow pipe rises from the boiler. Fill the system with water and check for leaks.

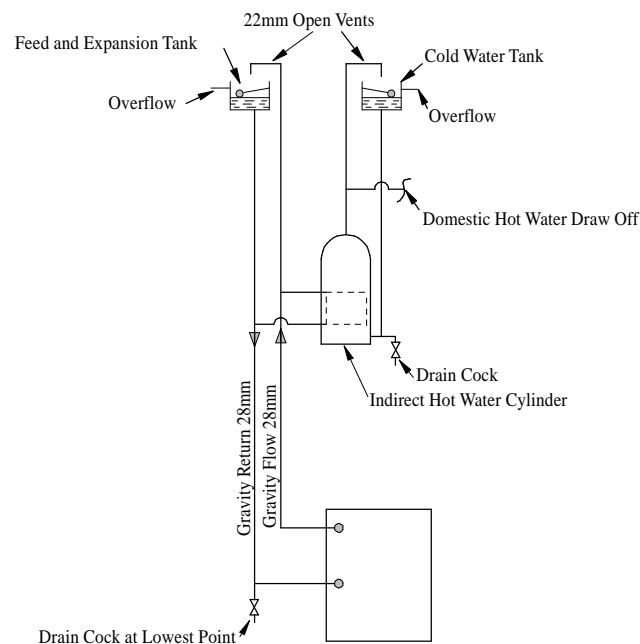

Fig. 6. Typical Gravity Hot Water System

FLUE CONNECTION AND INFILLING

Make the flue connection with the special 150°elbow part no. 010/AV12. Please note that this item is ordered separately from the appliance. The legs of the elbow may be cut on site to suit the chimney. Also note that the legs of the elbow are different lengths to enable some situations to be catered for by turning the elbow around.

The end of the flue pipe must line up with the centre-line of the chimney, and must also extend to the point where the chimney narrows to its final size. Any large voids must be filled and flaunching to the flue pipe to ensure that all soot deposits can be cleared when the appliance is swept, and to prevent problems with the operation of the appliance.

Ensure that the flue pipe is not obstructed or restricted in any way and that all joints are well sealed.

Before infilling cover the front of the appliance to protect it. Ensure that the flue pipe is central and then fill the space between the body of the appliance and the structural brickwork with vermiculite (e.g. micafil or similar) concrete. Ensure that there are

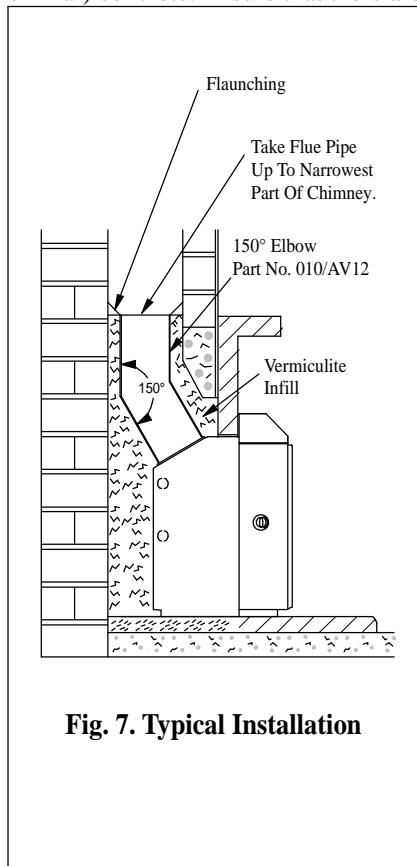

Fig. 7. Typical Installation

no air pockets. The recommended mix is six volumes of vermiculite granules to one volume of Portland cement thoroughly mixed together. Enough water should be added so that no more than one or two drops of water are released when a handful of the mixture is squeezed.

After filling with vermiculite concrete flaunch the top of the flue connector pipe to the chimney with lime mortar. Ensure that the flue pipe is well sealed to the chimney.

Make good the hole(s) in the chimney breast making sure that it is completely airtight. A typical installation is shown in Fig. 7.

In most installations it will be possible to sweep the chimney through the appliance. If this is not possible then some alternative means (such as a soot door), must be provided.

The free inset method of installation may be used instead of infilling. Details are available on request.

THERMOSTAT

Before lighting the fire check the cold setting distance of the thermostat.

With the control knob at the maximum setting the flap should be 18 mm from the air inlet as shown in Fig. 8. To adjust the distance slacken the locking nut and adjust as necessary. When set correctly re-tighten the locking nut. Ensure that the flap opens and closes freely as the knob is turned.

ASSEMBLY

Fit the side panels and hood onto the appliance. Instructions for this are enclosed with the panel pack.

Replace any internal parts previously removed.

PRE LIGHTING CHECK

Before initial lighting check the following points:

1. The bottom grate bars must all be fitted and should move freely and easily when the riddling mechanism is

operated.

2. The plates round the sides and back of the grate must be in position and sitting correctly.

3. The throat plate must be fitted in the roof of the appliance.

COMMISSIONING

On completion of the installation and

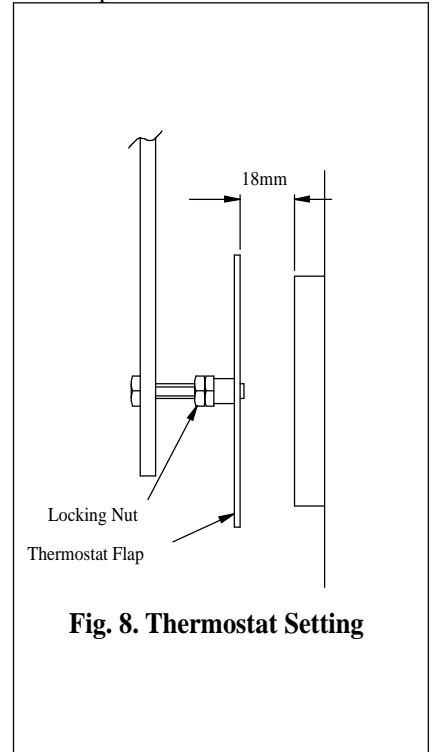

Fig. 8. Thermostat Setting

after allowing a suitable period of time for the fire cement and mortar to dry out, the fire should be lit and checked to ensure that smoke and fumes are taken from the appliance up the chimney and emitted safely. Also check all joints and seals.

On completion of the installation and commissioning please leave the operating instructions with the customer and advise on the use of the appliance.

FREESTANDING KIT

A freestanding kit is available. Details of dimensions and outputs are available on request.

CHARNWOOD LA20i OVERALL DIMENSIONS

(All dimensions are in mm)

Add-In Boiler May Be Fitted With
Tappings Either Side.

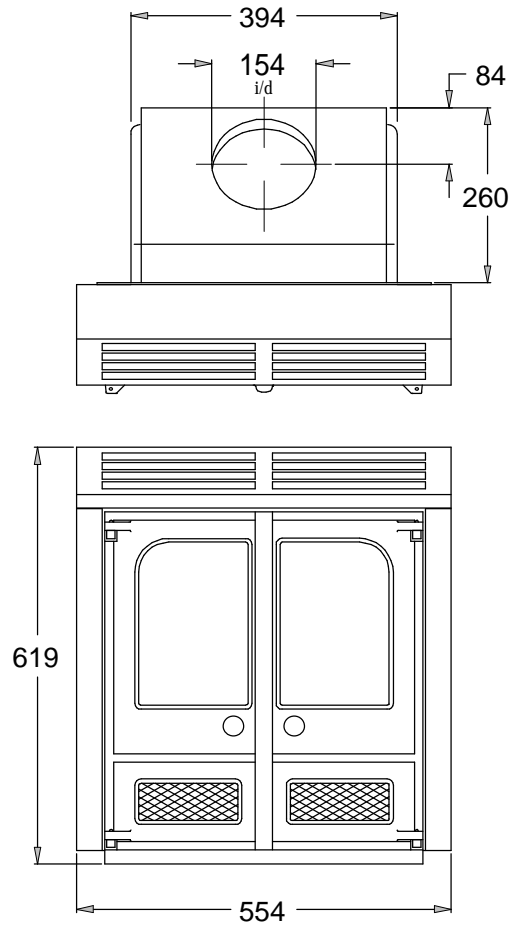
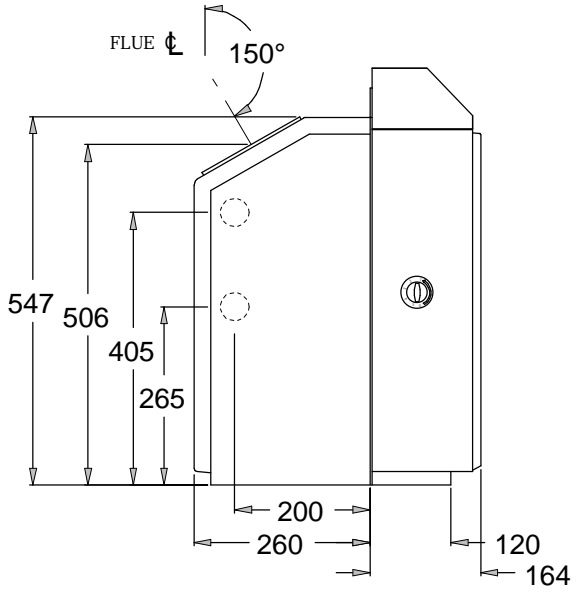

CHARNWOOD LA20 PARTS LIST

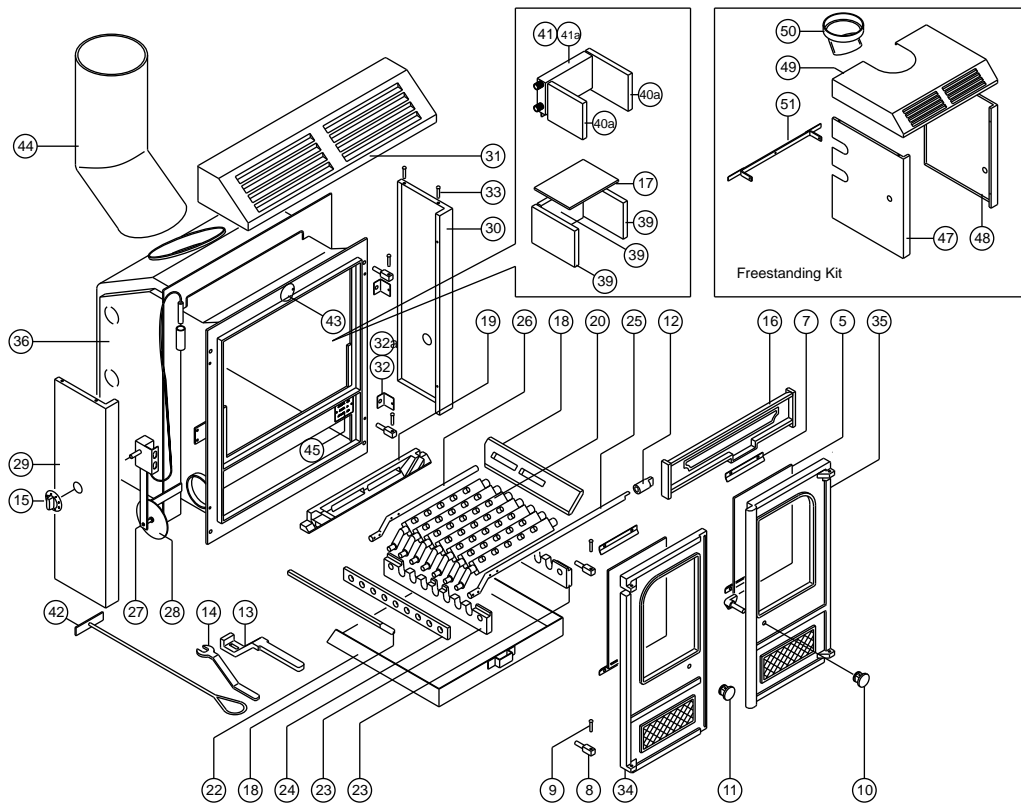

Item	Part	Description	Item	Part	Description
3*	008/RW35/S	Door Seal Set Incl. Adhesive	39	011/AV28S	Set Of Firebricks
4*	008/FW29	Door Seal Adhesive	40a	011/AV28BS	Set Of Firebricks (Use with boiler)
5	006/RW18	Glass Inc Glass Channel	41	010/AV25	Add-In Boiler (Steel)
6*	008/RW44/S	Glass Channel - set of 8	41a	010/AV25/SS	Add-In Boiler (Stainless Steel)
7	004/EW23	Glazing Bar	42	012/FW34	Scraper Tool
8	008/FW27	Hinge Post	43	008/RW09	Secondary Air Flap
9	008/BW39/S	Hinge Pin Set (4 per set)	44	010/AV12	150° Flue Pipe (Optional Extra)
10	008/RW43/A	Door Catch Assembly R.H.	45	012/AV11	Serial Number Label
11	002/HV12	Door Knob L.H. (Round)	46*	010/EW51	Ash Carrier (Optional Extra)
12	002/CG06	Riddler Knob	47	005/AV23	Side Panel L.H. (Freestanding Kit)
13	002/BW20	Riddler/Ashpan Tool	48	005/AV24	Side Panel R.H. (Freestanding Kit)
14	002/BW26	Door Opening Tool	49	005/AV22	Hood Panel (Freestanding Kit)
15	008/BW50	Thermostat Knob	50	002/AV13	150° Flue Elbow (Freestanding Kit)
16	002/FW07	Front Firebar	51	010/AV26	Rear Panel Bracket (Freestanding Kit)
17	002/AV31	Throat Plate			
18	002/HW15	Side Fire Plate			
19	002/HW16	Back Fire Plate			
20	002/CG01	Bottom Grate Bar			
21	002/CG01S7	Set Of Grate Bars (7per set)			
22	004/EW17	Ashpan			
23	002/HW30	Carrier Bar			
24	012/HW33	Mover Bar			
25	012/FW14	Riddler Rod			
26	012/CG05	Idler Rod			
27	008/BW49	Thermostat			
28	008/BW57	Thermostat Flap 90mm dia			
29	005/RW05	Side Panel L.H.			
30	005/RW04	Side Panel R.H.			
31	005/RW06	Hood Panel			
32	004/RW13	Panel Fixing Bracket			
32a	012/RW30	Hood & Panel Fixing Kit			
33	008/WW14S	Hood Fixing Pin Set (4)			
34	003/RW01	Door L.H.			
35	003/RW02	Door R.H.			
36	001/AV10	Firebox (LA20i)			

* These items are not shown on the drawing.



To obtain spare parts please contact your local stockist giving Model, Part No. and Description. In case of difficulty contact the manufacturer at the address shown. This drawing is for identification purposes only.

CHARNWOOD Bishops Way, Newport, Isle of Wight PO30 5WS, United Kingdom

T: +44 (0)1983 537799

F: +44 (0)1983 537788

charnwood@ajwells.co.uk

www.charnwood.com

Your Local Charnwood Dealer:



CHARWOOD Bishops Way, Newport, Isle of Wight PO30 5WS, United Kingdom
T: +44 (0)1983 537799 F: +44 (0)1983 537788 charnwood@ajwells.co.uk www.charnwood.com

A Division of A.J.Wells & Sons Limited Registered in England No. 03809371